

Planning, building and operating a free-standing privately-owned day theatre complex: a nine year experience

P E Papa Petros

Department of Gynaecology, Royal Perth Hospital, Perth, Western Australia

Building a privately-owned day surgery complex presents a unique challenge; how to marry the seemingly opposite requirements of high medical standards and reasonable profitability. Patient and doctor convenience are both served by locating the centre at the site of the surgeon's consulting rooms, as the patient may attend properly prepared, and have consultation and surgery disposed of on the same day. The ideal usage of such a complex is for high volume, rapid turnover cases, involving mainly healthy patients. Correction of planning mistakes can be ruinously expensive, and not only financially. Therefore the importance of critical analysis and thorough pre-planning cannot be over-emphasized. Safety is a key word. All protocols, whether they concern building, provision of equipment, surgical, anaesthetic or nursing practices, must have safety built in to their methodology. This specifically includes backup systems, and following that, simplicity, efficiency, and flexibility. It will be rewarded by significant savings in capital expenditure, time, running efficiency, job satisfaction and above all, patient satisfaction with the services provided.

Key words: Day surgery, building, planning

Introduction

The reason for building a privately-owned theatre must be determined with absolute clarity. The politicoeconomic climate must allow a reasonable return on the capital expended. i.e., no privately funded clinic can compete with a comprehensive state enterprise except in exceptional circumstances. If the day theatre complex is part of the consulting rooms, safety and efficiency are maximized.

Detailed below is the planning process and a nine year experience of running a privately-owned free-standing day theatre complex in a large Australian city encompassing almost 4000 cases.

Planning

Priorities

1. Patient safety;
2. Critical mass (patient numbers and turnover rate). This determines 3 & 4 below;

3. Building – cost effectiveness;
4. Operating costs (logistics of staffing). Servicing of capital costs, energy costs, disposables, cleaning and maintenance.

Every aspect of processes 1–4 above was thoroughly analysed prior to construction by the planning team, which consisted of two anaesthetists, surgeons from three different disciplines, a builder and a nurse theatre supervisor.

We attempted to have a 'backup' built into every system where possible. Patient safety was made non-negotiable, a decision being made at the outset that if it could not be adequately met because of expense, the project would not proceed. As the capital expenditure available was limited, critical mass also became important and priorities had to be laid down.

Prerequisites

1. Licensing from Department of Health authorities;
2. Building regulations from local authorities.

Depending on the county these regulations vary greatly. Indeed, in some states they may not even exist. In the latter instance it places a much greater responsibility on the surgeons involved. This is not all bad, as much

Accepted: December 1993

Correspondence and reprint requests to: PE Papa Petros, Suite 14A, Surgicentre 38 Ranelagh Cres., South Perth, Western Australia, 6151

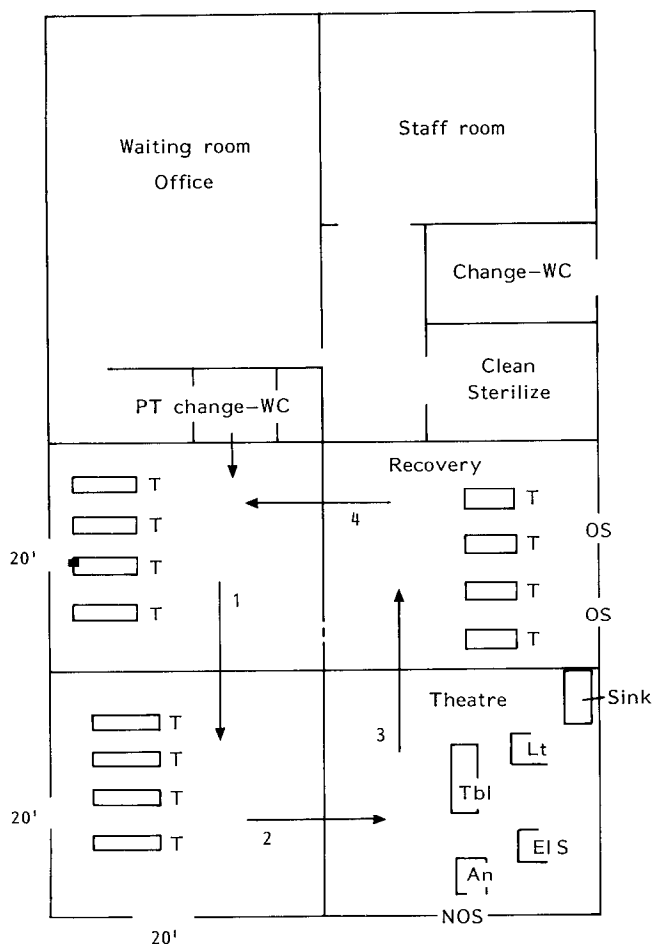

Figure 1. Actual floor plan of operating theatre complex. Arrows represent the patient flow from preanaesthetic room (1) to postanaesthetic room (2) to theatre (3) to recovery room (4), then back to preanaesthetic room (1). OS = oxygen/suction; An = anaesthetic machine; Tbi = operating table; Lt = operating light; NOS = wall-mounted nitrogen/oxygen/suction; T = patient trolley.

greater flexibility and operating efficiency can be achieved.

Capital costs

These were very carefully assessed, as they were fundamental to the viability of the unit.

Architecture

Figure 1 shows the actual plan of the theatre complex. A ground floor site is desirable in case a patient needs to be transferred to hospital. It would be efficient to have consulting rooms as part of the same complex. A ground floor complex allows elimination of an elevator – an expensive item. Optimal use of space is achieved by the circular flow pattern between the preanaesthetic rooms, theatre, and recovery room (see Figure 1). Floors were covered with heavy-duty linoleum with edges curled up to the walls. Doorways were 1200 cm wide, with double doors into the theatre, and a sliding door between the preanaesthetic rooms, and recovery and the anaesthetic

rooms, giving a space of 2400 cm, so that the patients could be properly supervised at all times by one nurse.

Fire control

Even in a ground floor situation attention must be paid to the logistics of what would occur in case of a fire and most especially, the rapid evacuation of patients and staff. A ground floor situation gives an extra degree of safety, but fire extinguishers and smoke alarms, and above all, evacuation drill, are minimal requirements.

Air conditioning

Air conditioning was provided, but only commercial units, one per room. Larger-than-normal units ensured rapid changes of air with minimal recirculation. Absolute filtered air conditioning is a very expensive item, which was not considered necessary in our experience. We have performed over 2000 laparoscopies without any infections whatsoever. More important, we felt, was the absolute exclusion of ‘dirty’ cases, i.e. no abscesses must ever be opened in such a day theatre.

Floor plan

The floor plan (see Figure 1) was found to be efficient, allowing for eight cases at a time. Provision of natural light in the theatre complex and preanaesthetic bays were found to be uplifting. We therefore chose to locate the sterilizing room behind the recovery room. Of course, it would have been more efficient to have the sterilizing room adjacent to the operating theatre.

Dimensions of rooms

The major rooms, preanaesthetic, theatre and recovery need to have minimum dimensions of 20 sq ft, ideally 24 × 24 ft. No dimensions are given for the other rooms; these can be varied according to requirements.

Flexibility may improve ‘critical mass’

A day theatre complex lends itself to specific usage. However, as the capital cost is large, it is important to build in flexibility so that the centre may be used by other specialities, i.e., ideally it should cover orthopaedic, general surgery, plastic surgery, gynaecology and eye surgery.

The ‘critical mass’ is the minimum amount of turnover needed to achieve a break-even point financially. The ideal use for the purpose-built free-standing day theatre is to deal with cases which are relatively minor and which lend themselves to high turnover, e.g. in gynaecology: laparoscopy, curettage, hysteroscopy, colposcopy/biopsy/cautery of cervix; and in orthopaedic surgery – arthroscopy, back manipulations, epidurals, etc. In low turnover situations, many procedures can be done purely under local anaesthesia, such as hernial repairs and various vaginal repairs.

Patient safety and comfort

Backup anaesthetic and emergency equipment

Backup systems for suction and oxygen were considered a prime necessity, non-negotiable prerequisites, as was equipment to deal with any acute emergency, such as cardiovascular collapse. Large cylinders supplying piped O₂ and N₂O were set up in a special security cage outside the main part of the building. N₂O and O₂ were piped to the theatre, and O₂ to the recovery room. Double-headed gas-driven suction was supplied, giving six separate suction units in all. A cardioverter, ECG monitor. Boyle's anaesthetic machine, a separate double electric sucker unit, a bipolar diathermy unit and a tilting theatre table with a gynaecological collapsible bottom end were installed. No flammable anaesthetic agents were used. A simple 'scavenger system' was installed (exit of the out-flow pipe directly to the outside air).

Sterilizing

Both a large autoclave, and a smaller 'flash' autoclave were provided. Theatre gowns, drapes and instruments were prepared before every list.

Patient trolleys

These should be as simple and as light as possible, with vertical fold-down side retaining bars (to save space), and with a head-tilting facility.

Operating spotlight

This was small, mobile, simple and effective and sufficient.

Absolute exclusion of 'dirty' cases

No abscesses were ever to be opened in theatre.

Intact reflexes

A decision was made never to transfer a patient from the operating theatre to the recovery room unless all reflexes were intact and the patient was properly conscious. This rule worked very well and had many unforeseen benefits, including the imperative for the surgeon to become adept and skilful in the use of local anaesthetics, thereby providing lighter general anaesthetic.

Local anaesthetics were used freely, especially during laparoscopy. This allowed the operation to be performed under lighter anaesthesia.

No opiates were used as it was found that this was the single most important factor in permitting same-day discharge of patients. Liberal use of local anaesthesia largely overcame the need for opiates.

Strict preoperative selection of patients

Only fit, healthy patients were anaesthetised in this facility, given the limited objectives of rapid turnover of minor cases. Initially an anaesthetic clinic was set up, but later on the surgeons pre-selected only healthy patients, and also performed any relevant preoperative tests. This saved much time from the patients' viewpoint. Also, by putting part of the obligation on the surgeon, it gave an extra dimension of cohesiveness and safety to the system. Of course, all patients were fully assessed preoperatively by the anaesthetist.

Preoperative preparation of the patient

Extensive preoperative explanations were given by the surgeon and the nursing staff. Printed letters of what to expect before and after operation were given out preoperatively. Specific operations had specific postoperative sheets issued. Included were after-hours telephone numbers for the surgeon.

Patient anxiety

The essence of a small complex is its personal nature, and by implication the warmth and supportive nature of the staff. Sensitive staff, by thorough explanation and support, can calm the most anxious patient. The most useful component for easing patient anxiety, however, was the fact that the preanaesthetic rooms were shared. Inevitably there was a patient, frequently with prior experience, who took it upon him/herself to calm down the other patients. Preoperative anxiolytic drugs are advisable and background music is also useful.

Specific techniques

These were left to the individual surgeon and anaesthetist. All anaesthetists working at the complex had had vast experience in outpatient anaesthesia. Other than the avoidance of opiates and the extensive usage of local anaesthetic supplement, no specific guidelines needed to be given. (It was found relatively early that vomiting due to opiates was relatively frequent and immensely distressing, to both patient and staff.)

Patient acceptance

Virtually every patient expressed a preference for the surgical facility as against being admitted to hospital. This was an unexpected but welcome finding.

Transfer of patients due to complications

Transfers were extremely rare. There was one case of undiagnosed ectopic pregnancy which had not bled significantly intraperitoneally. There were four cases of perforated uterus on curettage. As soon as the perforation was recognized, laparoscopy was performed. In no case was there any significant bleeding from the perforation.

Nevertheless, for medico-legal reasons the patient was transferred to hospital overnight. There was one case of scoliosis apnoea. This patient required oxygenation for 20 min or so, before spontaneous breathing recurred.

Some hints for operating efficiency

Time and motion studies

These demonstrated that the 'pressure points' delaying the turnover rate were during the induction of anaesthesia, transfer of patient onto the operating table and transferring the patient back off the trolley. An extra set of hands was needed here, and it was found that if the surgeon, the anaesthetist and the theatre staff cooperated, then the turnover was very smooth with minimal time delay. Theatre staff consisted of scrub nurse and two scout nurses. Everyone cooperated in the transfer of the patient and the transfer of the trolleys from room to room.

Multiple set-ups

These were used with their requirements for each case, pre-prepared in sterile pack, i.e. for curettes, a much reduced number of instruments was used and was limited, for instance, to a few dilators, sound, a choice of two curettes.

Patient belongings

The trolleys were all provided with a lower tray. On entry the patient changed to a special theatre gown and placed his/her belongings on the bottom of the trolley. This eliminated the problem of lockers, loss of belongings, etc.

Stock and servicing systems

A diary and protocols for ordering disposables and servicing of equipment was set up. Stable suppliers greatly reduced effort here, as they called in regularly and actually advised on the amount of stock needed.

Staff flexibility

Staff flexibility in job allocation was the key to the efficient functioning of the unit. There were no demarcation lines. Surgeons, anaesthetists and nursing staff all cooperated, where necessary, in every part of the theatre function, even at times assisting in washing down the walls and the floors, which were invariably performed by the nursing staff at the end of each operating list. The charge nurse also worked in the clinic, and one of the clerical staff had previous nursing experience. Therefore the patients were already familiar with two of the staff, so that going to an operating theatre was not such a frightening experience.

Conclusion

The healthcare system has been afflicted by excessive capital and running expenses due to 'over-engineering', i.e. using tertiary referral facilities for many procedures which could be safely and efficiently performed in a simpler facility. A small free-standing centre such as described is a perfect medium for the less invasive procedures certain to become routine in the 21st century.

Acknowledgements

I would like to thank Mrs Carole Yelas for her assistance in the preparation of this manuscript.

REPRINTS

We offer a reprints service in respect of all articles in this journal.

Companies: an article featuring your product or a new application provides its readers with an independent authoritative comment.

Reprints can be used by you to inform and educate your customers and staff about scientific or technical advances in subjects relevant to your business. They are a cost-effective, ethical way of promoting your company and its products.

For a quotation on your reprint requirements, please contact:

The Reprints Department, Butterworth-Heinemann Ltd., Linacre House, Jordan Hill, Oxford, OX2 8DP. Tel: +44 (0)865 310366. Fax: +44 (0)865 314519

BUTTERWORTH
HEINEMANN